



US 20130134450A1

(19) **United States**

(12) **Patent Application Publication**
CHANG et al.

(10) **Pub. No.: US 2013/0134450 A1**
(43) **Pub. Date: May 30, 2013**

(54) **ORGANIC LIGHT EMITTING DISPLAY APPARATUS**

(52) **U.S. Cl.**
USPC **257/88; 257/E51.018**

(76) Inventors: **Yeoung-Jin CHANG**, Yongin-City (KR); **Jae-Hwan OH**, Yongin-City (KR); **Seong-Hyun JIN**, Yongin-City (KR); **Won-Kyu KEE**, Yongin-City (KR)

(57) **ABSTRACT**

An organic light emitting display apparatus including sub pixels, each of the sub pixels including: first and second electrodes, the second electrode extending over the first electrode; and an intermediate layer disposed between the first and second electrodes, the intermediate layer including an emission layer, wherein a first portion of the first electrode, the second electrode, and the intermediate layer extends within a weak resonance region, the weak resonance region being configured to induce a first resonance of light generated by the emission layer between the first and second electrodes, and a second portion of the first electrode, the second electrode, and the intermediate layer extends within a strong resonance region, the strong resonance region being configured to induce a second resonance of light generated by the emission layer between the first and second electrodes, the second resonance being stronger than the first resonance.

(21) Appl. No.: **13/482,047**

(22) Filed: **May 29, 2012**

(30) **Foreign Application Priority Data**

Nov. 29, 2011 (KR) 10-2011-0126274

Publication Classification

(51) **Int. Cl.**
H01L 51/50 (2006.01)

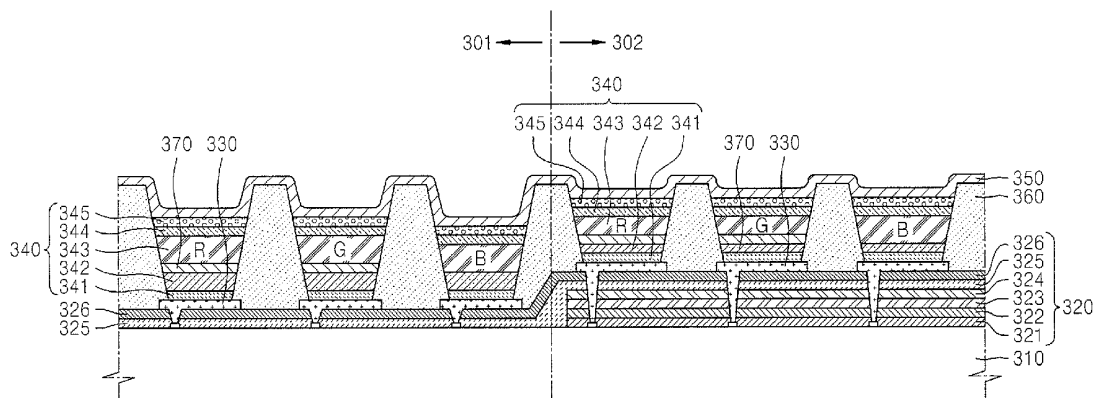

FIG. 1

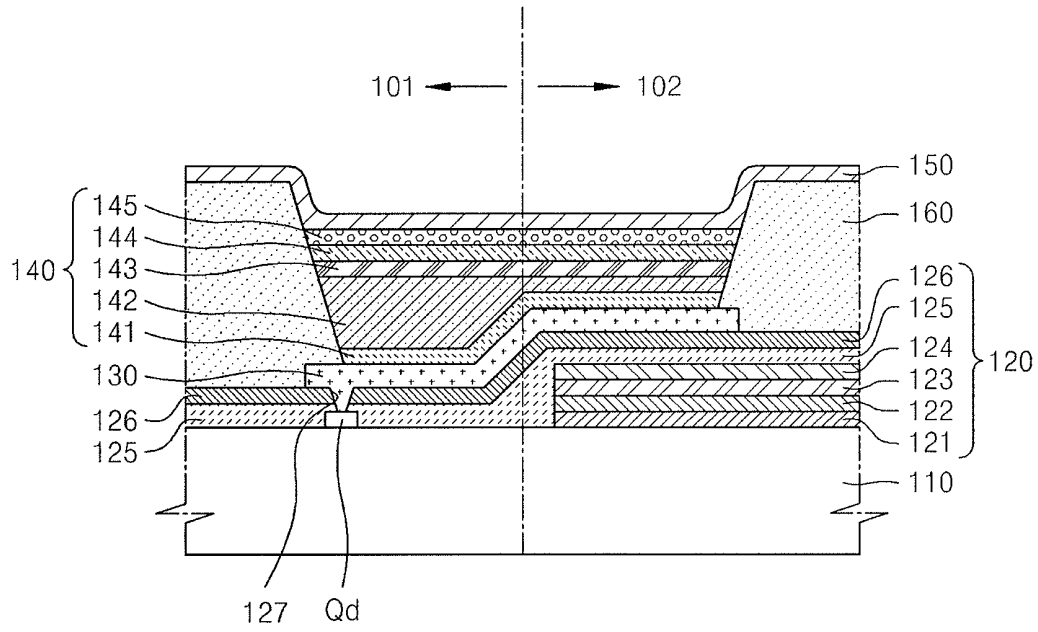

FIG. 2

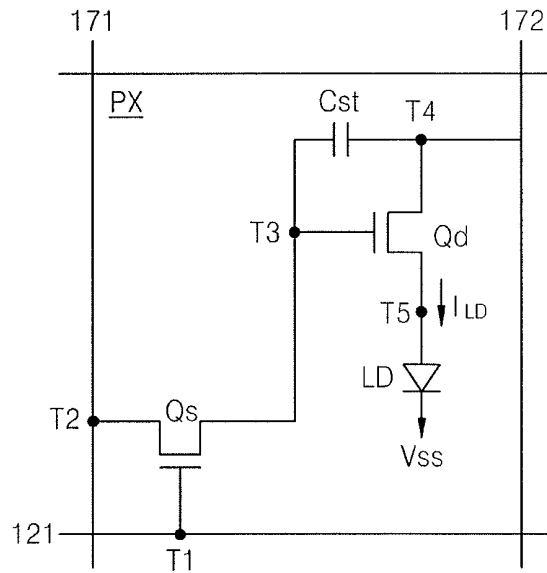

FIG. 3

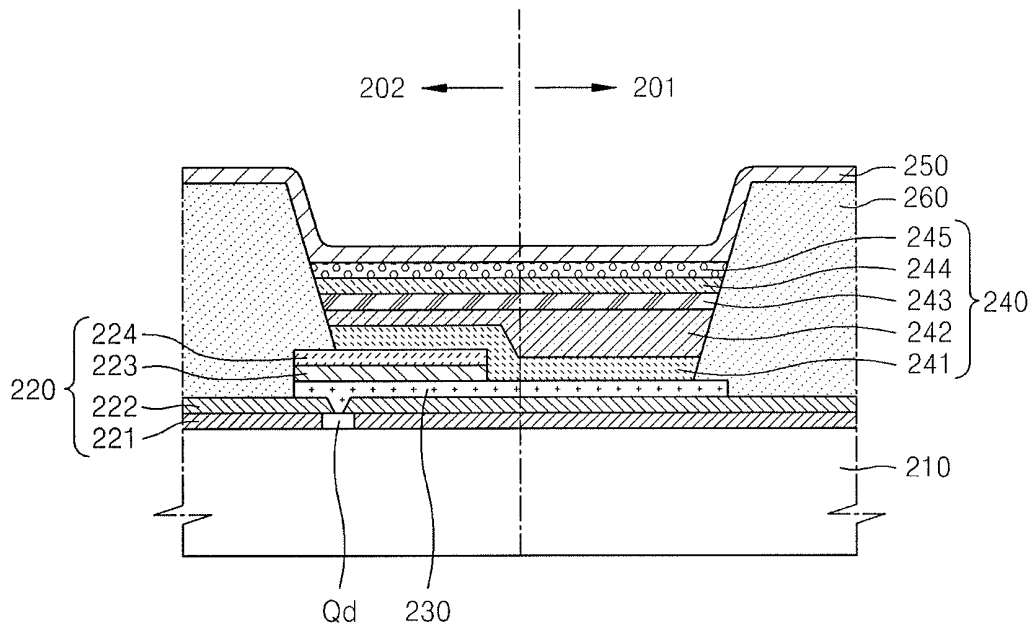

FIG. 4

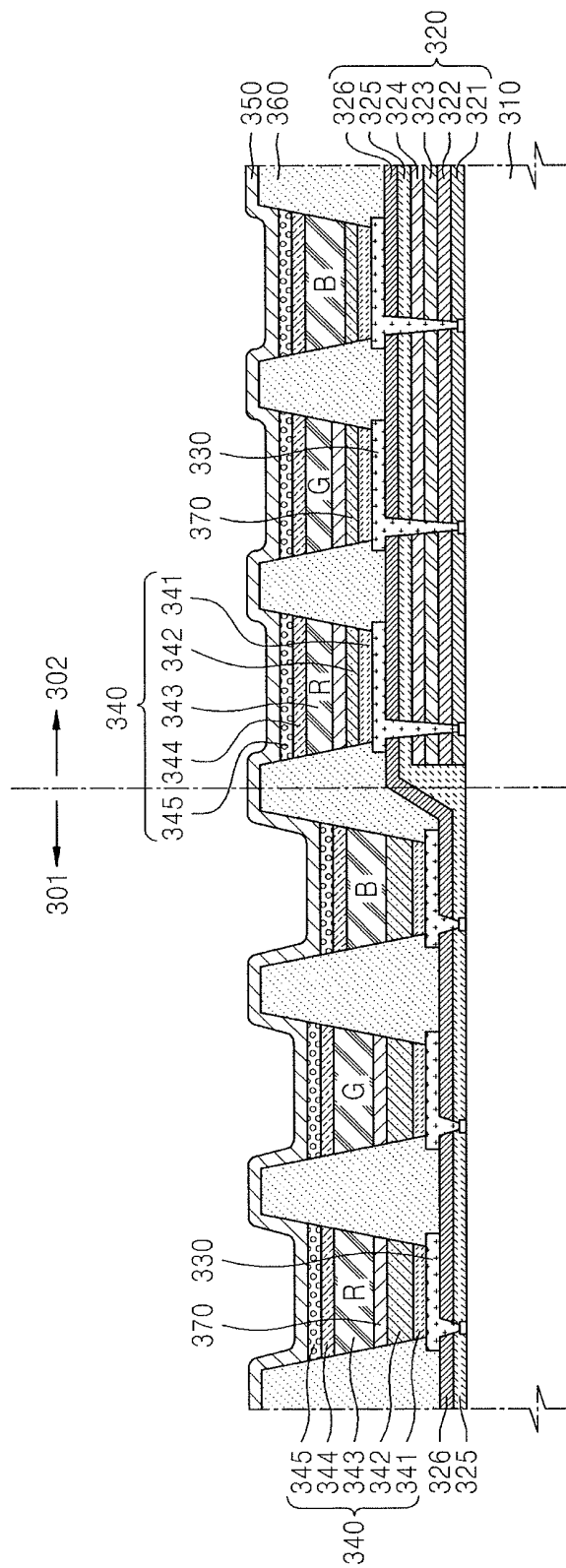
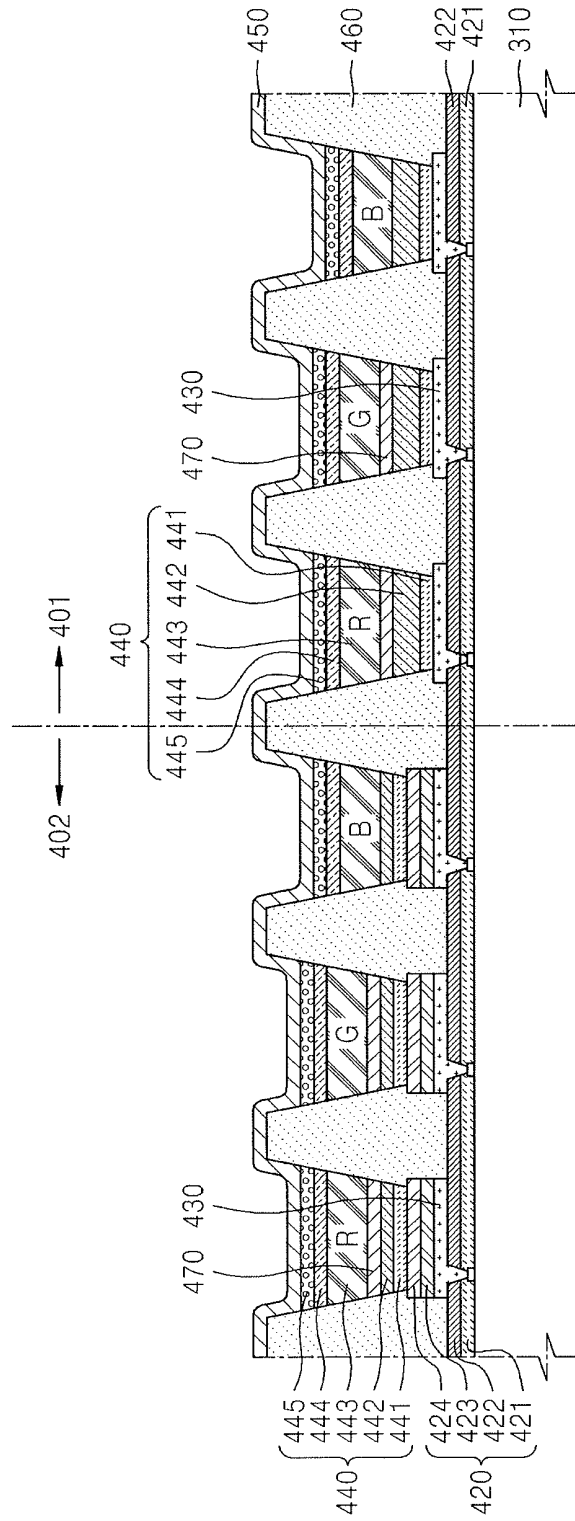

FIG. 5



**ORGANIC LIGHT EMITTING DISPLAY
APPARATUS****CROSS-REFERENCE TO RELATED PATENT
APPLICATION**

[0001] This application claims the benefit of Korean Patent Application No. 10-2011-0126274, filed on Nov. 29, 2011, in the Korean Intellectual Property Office, the disclosure of which is incorporated herein in its entirety by reference.

BACKGROUND

[0002] 1. Field

[0003] The embodiments relate to an organic light emitting display apparatus.

[0004] 2. Description of the Related Art

[0005] In general, an organic light emitting display apparatus displays colors by emitting light when holes and electrons that are injected from an anode and a cathode are recombined in an emission layer. The organic light emitting display has a stacked structure in which an emission layer is inserted between a pixel electrode that is an anode and a counter electrode that is a cathode.

[0006] A unit pixel of an organic light emitting display apparatus includes red, green, and blue sub pixels which are combined to display a desired color. In more detail, each sub pixel has a structure in which an emission layer for emitting red, green, or blue light is disposed between two electrodes, and a unit pixel displays a color by appropriately combining the red, green, and blue light.

[0007] Meanwhile, currently, in many cases, sub pixels are formed in a resonance structure in order to increase light extraction efficiency of an organic light emitting display apparatus. That is, the resonance structure induces constructive interference of light between two electrodes by forming one of an anode and a cathode for displaying an image as a translucent electrode, and forming the other as a total reflection electrode, and thus a quite enhanced light may be extracted from each sub pixel.

[0008] However, if a strong resonance structure is used, although light extraction efficiency is increased, viewing angle characteristics may deteriorate. For example, if a strong resonance structure is used, a significant brightness reduction and color shift may occur, according to a viewing angle.

[0009] Accordingly, in order to implement a product having high reliability, a new structure capable of improving light extraction efficiency and satisfactorily maintaining viewing angle characteristics is required.

SUMMARY

[0010] One or more embodiments may provide an organic light emitting display apparatus including sub pixels, each of the sub pixels including: first and second electrodes, the second electrode extending over the first electrode; and an intermediate layer disposed between the first and second electrodes, the intermediate layer including an emission layer, wherein a first portion of the first electrode, a first portion of the second electrode, and a first portion of the intermediate layer extends within a weak resonance region, the weak resonance region being configured to induce a first resonance of light generated by the emission layer between the first and second electrodes, and a second portion of the first electrode, a second portion of the second electrode, and a second portion of the intermediate layer extends within a strong resonance

region, the strong resonance region being configured to induce a second resonance of light generated by the emission layer between the first and second electrodes, the second resonance being stronger than the first resonance.

[0011] The organic light emitting display apparatus may further include a mirror layer for resonating the light between the first and second electrodes, the mirror layer including a first portion in the weak resonance region and a second portion in the strong resonance region, the second portion of the mirror layer being thicker than the first portion of the mirror layer. The mirror layer may include a dielectric mirror layer, a first portion of the dielectric mirror layer extending in the weak resonance region, and a second portion of the dielectric mirror layer extending in the strong resonance region. The dielectric mirror layer may include alternately stacked layers of silicon oxide (SiO_x) and silicon nitride (SiN_x), and the second portion of the dielectric mirror layer may include a larger number of stacked layers than the first portion of the dielectric mirror layer.

[0012] The mirror layer may include a dielectric mirror layer, a first portion of the dielectric mirror layer extending in the weak resonance region, and a second portion of the dielectric mirror layer extending in the strong resonance region, and a metal mirror layer extending only in the strong resonance region. The metal mirror layer may include a silver (Ag) layer, and the dielectric mirror layer may include alternately stacked layers of SiO_x and SiN_x.

[0013] The intermediate layer may further include a hole injection layer, a hole transporting layer, an electron injection layer, and an electron transporting layer for respectively injecting and transporting holes and electrons into the emission layer. A thickness of a portion of the hole transporting layer in the weak resonance region may be different from a thickness of a portion of the hole transporting layer in the strong resonance region, to facilitate adjusting resonance of light between the first and second electrodes.

[0014] One or more embodiments may provide an organic light emitting display apparatus including a plurality of unit pixels, each of the unit pixels including sub pixels for emitting light of different colors, the plurality of unit pixels including weak resonance unit pixels for inducing a first resonance, and strong resonance unit pixels for inducing a second resonance, the second resonance being stronger than the first resonance. Each of the sub pixels may include first and second electrodes, the second electrode extending over the first electrode, an intermediate layer disposed between the first and second electrodes, the intermediate layer including an emission layer and a mirror layer for resonating light generated by the emission layer between the first and second electrodes, the mirror layer including a first portion in the weak resonance unit pixels and a second portion in the strong resonance unit pixels, wherein the second portion of the mirror layer is thicker than the first portion of the mirror layer.

[0015] The mirror layer may include a dielectric mirror layer, a first portion of the dielectric mirror layer in the weak resonance unit pixels, and a second portion of the dielectric mirror layer in the strong resonance unit pixels. The dielectric mirror layer may include alternately stacked layers of silicon oxide (SiO_x) and silicon nitride (SiN_x), and the second portion of the dielectric mirror layer includes a larger number of stacked layers than the first portion of the dielectric mirror layer. The mirror layer may include a dielectric mirror layer, a first portion of the dielectric mirror layer in the sub pixels of the weak resonance unit pixels, and a second portion of the

dielectric mirror layer in the sub pixels of the strong resonance unit pixels; and a metal mirror layer formed in the sub pixels of only the strong resonance unit pixels. The metal mirror layer may include a silver (Ag) layer, and the dielectric mirror layer may include alternately stacked layers of SiOx and SiNx. The intermediate layer may further include a hole injection layer, a hole transporting layer, an electron injection layer, and an electron transporting layer for respectively injecting and transporting holes and electrons into the emission layer. A thickness of a portion of the hole transporting layer in the sub pixels of the weak resonance unit pixels is different from a thickness of a portion of the hole transportation layer in the sub pixels of the strong resonance unit pixels, to facilitate adjusting resonance of light between the first and second electrodes.

BRIEF DESCRIPTION OF THE DRAWINGS

[0016] The above and other features and advantages of the embodiments will become more apparent by describing in detail exemplary embodiments thereof with reference to the attached drawings in which:

[0017] FIG. 1 illustrates a cross-sectional view of a sub pixel of an organic light emitting display apparatus, according to an embodiment;

[0018] FIG. 2 illustrates an equivalent circuit diagram of the sub pixel illustrated in FIG. 1;

[0019] FIG. 3 illustrates a cross-sectional view of a sub pixel modified from FIG. 1, according to another embodiment;

[0020] FIG. 4 illustrates a cross-sectional view of unit pixels of an organic light emitting display apparatus, according to an embodiment; and

[0021] FIG. 5 illustrates a cross-sectional view of unit pixels modified from FIG. 4, according to another embodiment.

DETAILED DESCRIPTION

[0022] Hereinafter, the embodiments will be described in detail by explaining embodiments with reference to the attached drawings.

[0023] FIG. 1 illustrates a cross-sectional view of a sub pixel for forming a unit pixel of an organic light emitting display apparatus, according to an embodiment. FIG. 2 illustrates an equivalent circuit diagram of the sub pixel illustrated in FIG. 1. The unit pixel may include three-color sub pixels such as a red sub pixel R, a green sub pixel G, and a blue sub pixel B. FIG. 1 illustrates one sub pixel. The green and blue sub pixels G and B, may also have the structure illustrated in FIG. 1. Also, in the organic light emitting display apparatus, unit pixels each having the three-color sub pixels may be repeatedly aligned in row and column directions.

[0024] Referring to FIG. 2, a plurality of signal lines (121, 171, and 172) may be connected to a sub pixel PX.

[0025] The signal lines may include a scanning signal line 121 for transmitting a gate signal (or a scanning signal), a data line 171 for transmitting a data signal, and a driving voltage line 172 for transmitting a driving voltage.

[0026] The sub pixel PX may include a switching transistor Qs, a driving transistor Qd, a storage capacitor Cst, and an organic light emitting element LD.

[0027] The switching transistor Qs may include a control terminal T1, an input terminal T2, and an output terminal T3, wherein the control terminal T1 is connected to the scanning signal line 121, the input terminal T2 is connected to the data

line 171, and the output terminal T3 is connected to the driving transistor Qd. The switching transistor Qs may transmit the data signal received from the data line 171 to the driving transistor Qd in response to the scanning signal received from the scanning signal line 121.

[0028] The driving transistor Qd may include a control terminal T3, an input terminal T4, and an output terminal T5, wherein the control terminal T3 is connected to the switching transistor Qs, the input terminal T4 is connected to the driving voltage line 172, and the output terminal T5 is connected to the organic light emitting element LD. The output terminal T3 of the switching transistor Qs may function as the control terminal T3 of the driving transistor Qd. The driving transistor Qd may provide an output current ILD having a variable size according to a voltage applied between the control terminal T3 and the output terminal T5.

[0029] The storage capacitor Cst may be connected between the control terminal T3 and the input terminal T4 of the driving transistor Qd. The storage capacitor Cst may charge the data signal applied to the control terminal T3 of the driving transistor Qd and retain the data signal even after the switching transistor Qs is turned off.

[0030] The organic light emitting element LD may include a pixel electrode connected to the output terminal T5 of the driving transistor Qd (hereinafter referred to as a first electrode), a counter electrode connected to a common voltage line Vss (hereinafter referred to as a second electrode), and an emission layer disposed between the first and second electrodes and for emitting light due to a voltage applied between the first and second electrodes.

[0031] The detailed structure of the organic light emitting element LD will be described with reference to FIG. 1.

[0032] Referring to FIG. 1, initially, the driving transistor Qd may be formed on an insulating substrate 110 formed of transparent glass or plastic. Although not shown in FIG. 1, the switching transistor Qs and the signal lines (121, 171, and 172) illustrated in FIG. 2 may also be formed on the insulating substrate 110.

[0033] A mirror layer 120 may be a dielectric mirror layer formed on the driving transistor Qd. A first electrode 130 may be connected to the driving transistor Qd via a contact hole 127 formed on the mirror layer 120.

[0034] An intermediate layer 140, including an emission layer 143, and a second electrode 150 may be sequentially stacked on the first electrode 130, and a sealing layer (not shown) for preventing penetration of moisture and oxygen may be further formed on the second electrode 150. For example, the second electrode 150 may extend over the first electrode 130. A reference numeral 160 indicates a pixel defining layer.

[0035] The mirror layer 120 may reflect light generated by the emission layer 143 to be resonated between the first and second electrodes 130 and 150. The mirror layer 120 may divide each sub pixel into weak and strong resonance regions 101 and 102. For example, in FIG. 1, a left region of the sub pixel may be the weak resonance region 101, and a right region of the sub pixel may be the strong resonance region 102. A first portion of the mirror layer may be in the weak resonance region 101 and a second portion of the mirror layer may be in the strong resonance regions 102. The first portion of the mirror layer 120 may have a two-layered structure in which a silicon oxide (SiOx) layer 125 and a silicon nitride (SiNx) layer 126 are stacked, e.g., the silicon nitride (SiNx) layer 126 may be stacked on the silicon oxide (SiOx) layer

125. The second portion of the mirror layer **120** may have a four-layered structure in which SiNx layers **121** and **123** and SiOx layers **122** and **124** are stacked. Furthermore, the SiOx layer **125** and the SiNx layer **126** of the weak resonance region **101** may extend to the strong resonance region **102**. As such, the second portion of the mirror layer **120** (in the strong resonance region **102**) may have a six-layered structure. For example, the second portion of the mirror layer **120** (in the strong resonance region **102**) may include a larger number of stacked layers than the first portion of the mirror layer **120** (in the weak resonance region **101**).

[0036] In comparison to the mirror layer **120** having a relatively small number of stacked layers, the mirror layer **120** having a relatively large number of stacked layers may resonate light generated by the emission layer **143** between the first and second electrodes **130** and **150** more strongly. Accordingly, the strong resonance region **102**, in which the mirror layer **120** includes a larger number of stacked layers, may induce a strong resonance in comparison to the weak resonance region **101**. Thus, the strong resonance region **102** may have a higher light extraction efficiency than the weak resonance region **101**. The weak resonance region **101**, inducing a relatively weak resonance, may have a relatively low light extraction efficiency, but a relatively large viewing angle in comparison to the strong resonance region **102**. For example, the strong resonance region **102** may increase light extraction efficiency and the weak resonance region **101** may ensure a sufficient viewing angle.

[0037] Also, according to the current embodiment, in addition to the mirror layer **120**, the intermediate layer **140** (including the emission layer **143**) may also be structured to divide the sub pixel into the weak and strong resonance regions **101** and **102**. In the intermediate layer **140**, a hole injection layer **141** and a hole transporting layer **142** (for respectively injecting and transporting holes into the emission layer **143**), the emission layer **143**, an electron injection layer **144** and an electron transporting layer **145** (for respectively injecting and transporting electrons into the emission layer **143**), have different thicknesses according to the weak and strong resonance regions **101** and **102**. The thickness of the hole transporting layer **142**, in particular, may vary significantly between the weak and strong resonance regions **101** and **102**. For example, the hole transporting layer **142** may have a significantly greater thickness in the weak resonance region **101** than in the strong resonance region **102**. In general, resonance may induce constructive interference of light. Light generated by the emission layer **143** may efficiently cause constructive interference at a certain gap between the first and second electrodes **130** and **150**. Accordingly, if the gap is adjusted, resonance may be induced strongly or weakly. In the current embodiment, the sub pixel may also be divided into the weak and strong resonance regions **101** and **102** by varying the thickness of the hole transporting layer **142** according to the weak and strong resonance regions **101** and **102**.

[0038] Light generated by the emission layer **143** of one sub pixel may be emitted at different intensities according to the weak and strong resonance regions **101** and **102**. For example, the strong resonance region **102** may emit light having a relatively high light extraction efficiency, and the weak resonance region **101** may emit light having a relatively low light extraction efficiency but ensuring a sufficient viewing angle. Consequently, light emitted from the weak resonance region **101** and light emitted from the strong resonance

region **102** may be mixed in one sub pixel. An effect of improving both light extraction efficiency and viewing angle characteristics may be achieved by mixing weakly resonated light and strongly resonated light.

[0039] Light emitted from the strong resonance region **102** has increased intensity and directionality due to strong resonance. Accordingly, light extraction efficiency may be increased. However, due to a high directionality, a brightness level or a color coordinate of light may greatly vary even when a viewing angle is slightly out of the center of a screen. On the other hand, the weak resonance region **101** may not increase light extraction efficiency but may have better viewing angle characteristics than the strong resonance region **102**. Therefore, an effect of improving light extraction efficiency may be achieved in comparison to a sub pixel including only the weak resonance region **101**, while better viewing angle characteristics may be achieved in comparison to a sub pixel including only the strong resonance region **102**.

[0040] Accordingly, if the organic light emitting display apparatus according to the current embodiment is used, both light extraction efficiency and viewing angle characteristics may be improved.

[0041] Although the weak and strong resonance regions **101** and **102** of the sub pixel have similar sizes in the above embodiment, in some cases, the weak and strong resonance regions **101** and **102** may be asymmetrically formed to emphasize one effect. According to some embodiments, the strong resonance region **102** may have a larger size than the weak resonance region **101** in order to maximize light extraction efficiency. According to some embodiments, the weak resonance region **101** may have a larger size than the strong resonance region **102** in order to maximize viewing angle characteristics.

[0042] FIG. 3 illustrates a cross-sectional view of a sub pixel modified from FIG. 1, according to another embodiment.

[0043] The sub pixel according to the current embodiment (illustrated in FIG. 3) also includes weak and strong resonance regions **201** and **202**.

[0044] For example, like the sub pixel illustrated in FIG. 1, the sub pixel illustrated in FIG. 3 has a structure in which a mirror layer **220**, a first electrode **230**, an intermediate layer **240**, and a second electrode **250** are sequentially stacked on a substrate **210**, and the mirror layer **220** of the strong resonance region **202** is relatively thicker than that of the weak resonance region **201**.

[0045] However, in the current embodiment, the mirror layer **220** of the strong resonance region **202** may further include a metal mirror layer (**223** and **224**), while the mirror layer **220** of the weak resonance region **201** may not. The mirror layer **220** of the weak resonance region **201** may be formed as a dielectric mirror layer having a two-layered structure in which a SiNx layer **221** and a SiOx layer **222** are stacked. The mirror layer **220** of the strong resonance region **202** may further include a metal mirror layer including a silver (Ag) layer **223** and an indium tin oxide (ITO) layer **224** sequentially stacked on the first electrode **230** (formed on the dielectric mirror layer). Due to the above enhanced structure, the strong resonance region **202** may induce a more enhanced resonance in comparison to the weak resonance region **201**, and thus light extraction efficiency may be improved. A problem of narrowing a viewing angle may be compensated by the weak resonance region **201**, as described above in relation to FIG. 1.

[0046] The intermediate layer 240 may also be structured as described above for the previous embodiment (illustrated in FIG. 1). For example, in the intermediate layer 240, a hole injection layer 241, a hole transporting layer 242, an emission layer 243, an electron transporting layer 244, and an electron injection layer 245, may have different thicknesses according to the weak and strong resonance regions 201 and 202, such that the strong resonance region 202 induces a stronger resonance. The thickness of the hole transporting layer 242, in particular, may vary significantly between the weak and strong resonance regions 201 and 202. For example, the hole transporting layer 242 may have a significantly greater thickness in the weak resonance region 201 than in the strong resonance region 202. The organic light emitting display apparatus may further include a pixel defining layer 260

[0047] The organic light emitting display apparatus according to the current embodiment may achieve an effect of improving both light extraction efficiency and viewing angle characteristics.

[0048] Although one sub pixel may be divided into a strong resonance region and a weak resonance region, as described above, the principles described above may be applied to units of pixels as described below.

[0049] FIG. 4 illustrates a cross-sectional view of unit pixels of an organic light emitting display apparatus, according to an embodiment. The sub pixel structure illustrated in FIG. 1 is incorporated in the units of pixels of FIG. 4.

[0050] In general, a pixel, i.e., a unit pixel, includes three-color (red, green, and blue) sub pixels. In FIG. 4, weak and strong resonance unit pixels 301 and 302 may be alternately aligned. On a plane, the weak and strong resonance unit pixels 301 and 302 may be alternately aligned in row and column directions.

[0051] In the weak resonance unit pixel 301, a mirror layer 320 on a substrate 310 has a two-layered structure in which a SiOx layer 325 and a SiNx layer 326 are stacked. However, in the strong resonance unit pixel 302, the mirror layer 320 has a six-layered structure including the two-layered structure (325 and 326) and a four-layered structure in which SiNx layers 321 and 323 and SiOx layers 322 and 324 are stacked. A pixel defining layer 360 and a gap adjusting electrode 370 may further be provided. The gap adjusting electrode may adjust a gap between the first and second electrodes 330 and 350 to be appropriate for a resonance condition of each sub pixel.

[0052] An intermediate layer 340 between first and second electrodes 330 and 350 may have slightly different structures when same-color sub pixels of the weak and strong resonance unit pixels 301 and 302 are compared. In the intermediate layer 340, a hole injection layer 341, a hole transporting layer 342, an emission layer 343, an electron transporting layer 344, and an electron injection layer 345, particularly, the hole transporting layer 342 may have different thicknesses when same-color sub pixels of the weak and strong resonance unit pixels 301 and 302 are compared. Thus, as described above in relation to FIG. 1, the strong resonance unit pixel 302 may induce a stronger resonance.

[0053] Accordingly, light emitted from the weak resonance unit pixel 301 and light emitted from the strong resonance unit pixel 302 may be mixed. An effect of improving both light extraction efficiency and viewing angle characteristics may be achieved by mixing weakly resonated light and strongly resonated light.

[0054] FIG. 5 illustrates a cross-sectional view of unit pixels according to another embodiment. The sub pixel structure illustrated in FIG. 3 is incorporated in the units of pixels of FIG. 5.

[0055] Weak and strong resonance unit pixels 401 and 402 each including three-color (red, green, and blue) sub pixels may be alternately aligned. On a plane, the weak and strong resonance unit pixels 401 and 402 may be alternately aligned in row and column directions.

[0056] A mirror layer 420 of the weak resonance unit pixel 401 may be formed as a dielectric mirror layer having a two-layered structure in which a SiNx layer 421 and a SiOx layer 422 are stacked. The mirror layer 420 of the strong resonance unit pixel 402 may further include a metal mirror layer including an Ag layer 423 and an ITO layer 424 sequentially stacked on a first electrode 430 (formed on the dielectric mirror layer). Due to the above enhanced structure, the strong resonance unit pixel 402 may induce a much enhanced resonance in comparison to the weak resonance unit pixel 401. Thus, light extraction efficiency may be improved. A problem of narrowing a viewing angle may be compensated by the weak resonance unit pixel 401, as described above in relation to FIG. 1.

[0057] An intermediate layer 440 between first and second electrodes 430 and 450 may have slightly different structures when same-color sub pixels of the weak and strong resonance unit pixels 401 and 402 are compared. In the intermediate layer 440, a hole injection layer 441, a hole transporting layer 442, an emission layer 443, an electron transporting layer 444, and an electron injection layer 445, particularly, the hole transporting layer 442 may have different thicknesses when same-color sub pixels of the weak and strong resonance unit pixels 401 and 402 are compared. Thus, as described above in relation to FIG. 3, the strong resonance unit pixel 402 may induce a stronger resonance.

[0058] A pixel defining layer 460, a gap adjusting electrode 470 may also be provided. The gap adjusting electrode 470 may adjust a gap between the first and second electrodes 430 and 450 to be appropriate for a resonance condition of each sub pixel.

[0059] Accordingly, light emitted from the weak resonance unit pixel 401 and light emitted from the strong resonance unit pixel 402 may be mixed. An effect of improving both light extraction efficiency and viewing angle characteristics may be achieved by mixing weakly resonated light and strongly resonated light.

[0060] As described above, since an organic light emitting display apparatus according to an embodiment may include strong and weak resonance structures, both light extraction efficiency and viewing angle characteristics may be improved. Thus, a product having a high reliability may be implemented by using the organic light emitting display apparatus.

[0061] While the embodiments have been particularly shown and described with reference to exemplary embodiments thereof, it will be understood by those of ordinary skill in the art that various changes in form and details may be made therein without departing from the spirit and scope of the present invention as defined by the following claims.

What is claimed is:

1. An organic light emitting display apparatus comprising sub pixels, each of the sub pixels including:
first and second electrodes, the second electrode extending over the first electrode; and

- an intermediate layer disposed between the first and second electrodes, the intermediate layer including an emission layer, wherein:
- a first portion of the first electrode, a first portion of the second electrode, and a first portion of the intermediate layer extends within a weak resonance region, the weak resonance region being configured to induce a first resonance of light generated by the emission layer between the first and second electrodes, and
- a second portion of the first electrode, a second portion of the second electrode, and a second portion of the intermediate layer extends within a strong resonance region, the strong resonance region being configured to induce a second resonance of light generated by the emission layer between the first and second electrodes, the second resonance being stronger than the first resonance.
- 2.** The organic light emitting display apparatus of claim **1**, further including a mirror layer for resonating the light between the first and second electrodes, the mirror layer including a first portion in the weak resonance region and a second portion in the strong resonance region, the second portion of the mirror layer being thicker than the first portion of the mirror layer.
- 3.** The organic light emitting display apparatus of claim **2**, wherein the mirror layer includes a dielectric mirror layer, a first portion of the dielectric mirror layer extending in the weak resonance region, and a second portion of the dielectric mirror layer extending in the strong resonance region.
- 4.** The organic light emitting display apparatus of claim **3**, wherein:
- the dielectric mirror layer includes alternately stacked layers of silicon oxide (SiO_x) and silicon nitride (SiN_x), and
- the second portion of the dielectric mirror layer includes a larger number of stacked layers than the first portion of the dielectric mirror layer.
- 5.** The organic light emitting display apparatus of claim **2**, wherein the mirror layer includes:
- a dielectric mirror layer, a first portion of the dielectric mirror layer extending in the weak resonance region, and a second portion of the dielectric mirror layer extending in the strong resonance region; and
- a metal mirror layer extending only in the strong resonance region.
- 6.** The organic light emitting display apparatus of claim **5**, wherein:
- the metal mirror layer includes a silver (Ag) layer, and
- the dielectric mirror layer includes alternately stacked layers of SiO_x and SiN_x.
- 7.** The organic light emitting display apparatus of claim **1**, wherein the intermediate layer further includes a hole injection layer, a hole transporting layer, an electron injection layer, and an electron transporting layer for respectively injecting and transporting holes and electrons into the emission layer.
- 8.** The organic light emitting display apparatus of claim **7**, wherein a thickness of a portion of the hole transporting layer in the weak resonance region is different from a thickness of a portion of the hole transporting layer in the strong resonance region, to facilitate adjusting resonance of light between the first and second electrodes.
- 9.** An organic light emitting display apparatus comprising a plurality of unit pixels, each of the unit pixels including sub pixels for emitting light of different colors, the plurality of unit pixels including:
- weak resonance unit pixels for inducing a first resonance, and
- strong resonance unit pixels for inducing a second resonance, the second resonance being stronger than the first resonance.
- 10.** The organic light emitting display apparatus of claim **9**, wherein each of the sub pixels includes:
- a first and second electrode, the second electrode extending over the first electrode;
- an intermediate layer disposed between the first and second electrodes, the intermediate layer including an emission layer; and
- a mirror layer for resonating light generated by the emission layer between the first and second electrodes, the mirror layer including a first portion in the weak resonance unit pixels and a second portion in the strong resonance unit pixels,
- wherein the second portion of the mirror layer is thicker than the first portion of the mirror layer.
- 11.** The organic light emitting display apparatus of claim **10**, wherein the mirror layer includes a dielectric mirror layer, a first portion of the dielectric mirror layer being in the weak resonance unit pixels, and a second portion of the dielectric mirror layer being in the strong resonance unit pixels.
- 12.** The organic light emitting display apparatus of claim **11**, wherein:
- the dielectric mirror layer includes alternately stacked layers of silicon oxide (SiO_x) and silicon nitride (SiN_x), and
- the second portion of the dielectric mirror layer includes a larger number of stacked layers than the first portion of the dielectric mirror layer.
- 13.** The organic light emitting display apparatus of claim **10**, wherein the mirror layer includes:
- a dielectric mirror layer, a first portion of the dielectric mirror layer being in the sub pixels of the weak resonance unit pixels, and a second portion of the dielectric mirror layer being in the sub pixels of the strong resonance unit pixels; and
- a metal mirror layer formed in the sub pixels of only the strong resonance unit pixels.
- 13.** The organic light emitting display apparatus of claim **13**, wherein:
- the metal mirror layer includes a silver (Ag) layer, and
- the dielectric mirror layer includes alternately stacked layers of SiO_x and SiN_x.
- 15.** The organic light emitting display apparatus of claim **10**, wherein the intermediate layer further includes a hole injection layer, a hole transporting layer, an electron injection layer, and an electron transporting layer for respectively injecting and transporting holes and electrons into the emission layer.
- 16.** The organic light emitting display apparatus of claim **15**, wherein a thickness of a portion of the hole transporting layer in the sub pixels of the weak resonance unit pixels is different from a thickness of a portion of the hole transporting layer in the sub pixels of the strong resonance unit pixels, to facilitate adjusting resonance of light between the first and second electrodes.

* * * * *

专利名称(译)	有机发光显示装置		
公开(公告)号	US20130134450A1	公开(公告)日	2013-05-30
申请号	US13/482047	申请日	2012-05-29
[标]申请(专利权)人(译)	常YEOUNG金 OH JAE HWAN JIN SEONG HYUN KEE WON KYU		
申请(专利权)人(译)	常, YEOUNG-JIN OH, JAE-HWAN 金, 晟HYUN KEE, WON-KYU		
当前申请(专利权)人(译)	三星DISPLAY CO., LTD.		
[标]发明人	CHANG YEOUNG JIN OH JAE HWAN JIN SEONG HYUN KEE WON KYU		
发明人	CHANG, YEOUNG-JIN OH, JAE-HWAN JIN, SEONG-HYUN KEE, WON-KYU		
IPC分类号	H01L51/50		
CPC分类号	H01L27/3211 H01L51/5265 H01S3/08086		
优先权	1020110126274 2011-11-29 KR		
其他公开文献	US9013094		
外部链接	Espacenet USPTO		

摘要(译)

一种有机发光显示装置，包括子像素，每个子像素包括：第一和第二电极，第二电极在第一电极上延伸；中间层，设置在第一电极和第二电极之间，中间层包括发光层，其中第一电极，第二电极和中间层的第一部分在弱谐振区域内延伸，弱谐振区域被配置在第一电极和第二电极之间产生由发光层产生的光的第一谐振，并且第一电极，第二电极和中间层的第二部分在强共振区域内延伸，强共振区域被配置为在第一和第二电极之间引发由发射层产生的光的第二谐振，第二谐振强于第一谐振。

